

HUBER RakeMax® Multi-Rake Bar Screen



Reliable, sturdy travelling screen

- Very high screenings discharge capacity
- Low headloss
- Low installation height above ground level even in deep channels

►► Design and function

The HUBER RakeMax® Multi-Rake Bar Screen is perfectly suited to both municipal and industrial wastewater, and process water screening. The cleaning elements, attached to the chain system, can easily be adjusted to different requirements. These elements can be conventional rakes, or brushes, or plastic wipers.

As the cleaning elements are changeable, the screenings discharge capacity is then adjustable. This is especially favourable for high solids loads.

The installation height of the RakeMax® above ground level is very small and only dependent, even in case of deep channels, on the installation height of screenings transport or washing units.

Both ends of the cleaning elements are connected to drive chains. Each chain is driven by a sprocket on a common shaft and a flange mounted gear motor. Furthermore, defined meshing of the cleaning rakes with the bar rack ensures a high operating reliability. If the screen operation is blocked, a mechanical overload protection interrupts the operation.

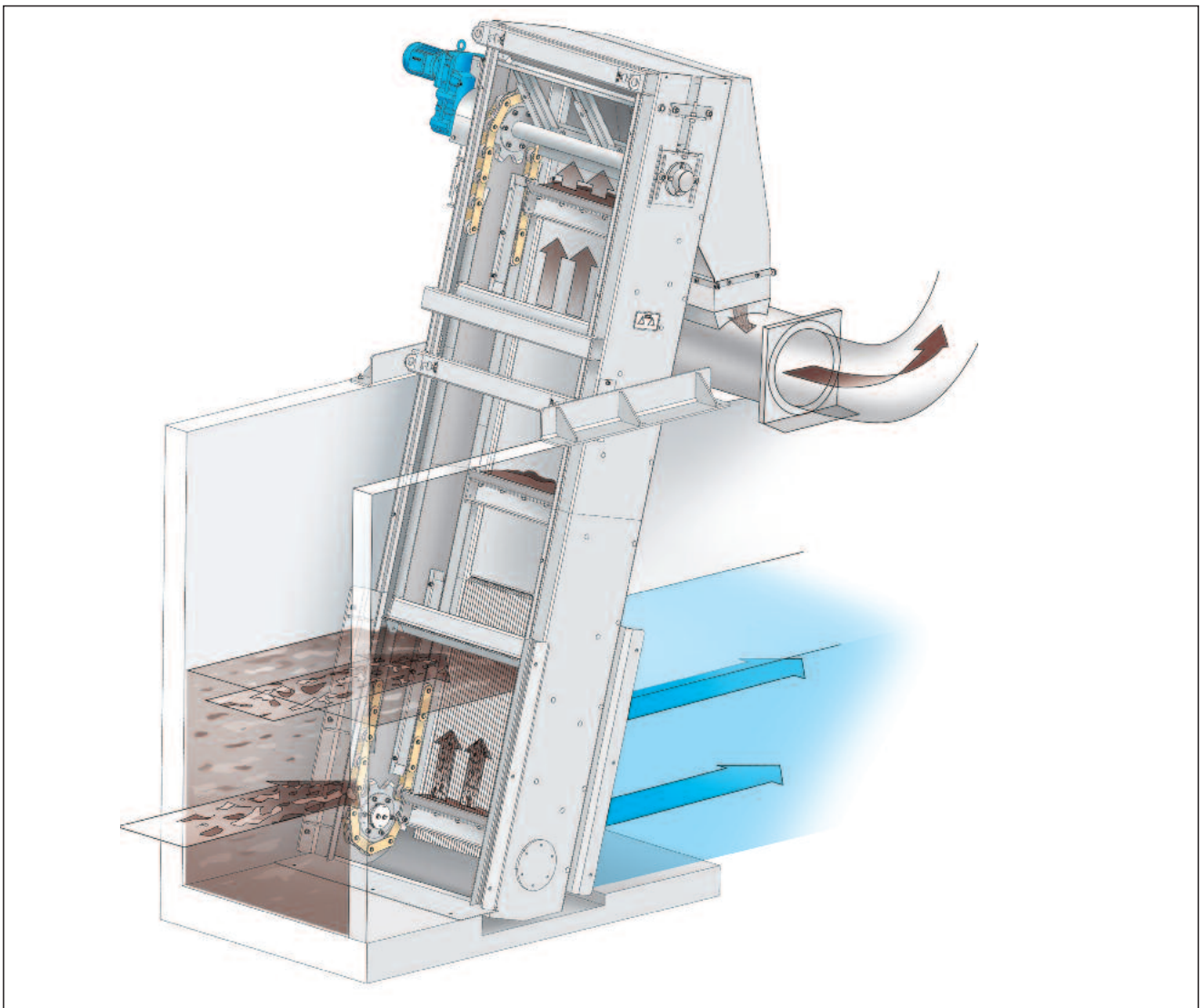

Schematic drawing of the HUBER RakeMax® Multi-Rake Bar Screen

➤➤ The benefits of the RakeMax® Screen at a glance:

- Very low headloss – high separation efficiency
- Defined meshing of the cleaning rakes with the bar rack ensures a high operating reliability.
- Screen installation possible without a bottom step
- Compact design with a low installation height above ground level
- Completely odour-encased screen with easy to remove covers
- Easy-to-retrofit into existing channels, installation without channel recesses possible
- The screen consists of a self-supporting folded stainless steel profile so that it can easily be lifted out of the channel.
- Not hindered by gravel or grit
- Simple and easy-to-access chain tensioning unit
- All parts in contact with medium (except the chain, drive and bearing) are made of immersion pickled stainless steel, optional stainless steel chains.
- High screenings discharge capacity through adjustable cleaning elements
- Independently replaceable rake and comb plates

➤➤ RakeMax® Features

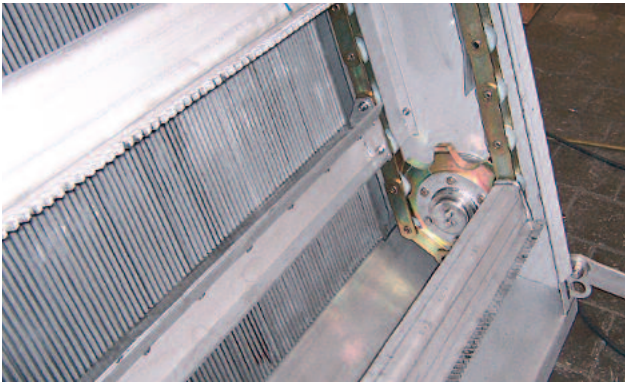

Drive chain made of hardened wear-resistant steel with plastic protection rollers. The chain and pinion are zinc-plated and yellow chromated for durable corrosion protection.

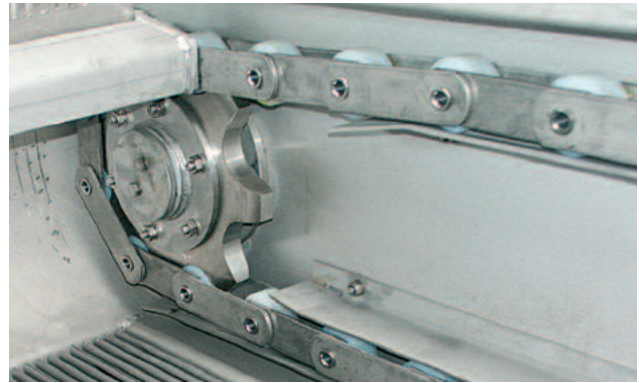

Optional stainless steel pinions and chains. Irrespective of the design, the bottom bearings are wear-resistant, maintenance-free ceramic bearings.



Screens with small bar spacings (here 6 mm) have specially shaped bars (tear drop design). The pressure loss is thus significantly reduced compared to flat or trapezoidal bars. The special bar shape prevents jamming of solids in the bar spacings. The screen proves thus its insensitivity to grit and gravel.



A control-independent safety system (torque compensator) reliably protects the screen against damage giving an electric signal. The specific design principle ensures high adjustability and continuous control.

➤ Installation examples:



Universally applicable HUBER RakeMax® screen for big channel widths ...



... and big discharge heights

➤ Screen sizes:

Channel width:	up to 4000 mm
Discharge height above channel floor:	up to 20 m
Bar spacing: (Smaller spacings are available upon request.)	≥ 6 mm
Installation angle:	70° – 85°



Rear view of a HUBER RakeMax® Screen with subsequent Wash Press WAP/SL

HUBER SE

Industriepark Erasbach A1 · D-92334 Berching
 Phone: + 49 - 84 62 - 201 - 0 · Fax: + 49 - 84 62 - 201 - 810
 info@huber.de · Internet: www.huber.de

Subject to technical modification
 0,0 / 7 – 3.2011 – 8.2004

HUBER RakeMax® Screen