

ROTAMAT® Pipestrainer



- Fine screening of small wastewater flows (up to 7 l/s)
- Removal of hairs, fibres and fine suspended material
- Increased operating stability of membrane plants (with hollow fibre and plate modules)
- Sludge thickening
- Brown water screening, wash water treatment, service water screening

►► The situation

Wash water is increasingly required for many stages of municipal and industrial wastewater treatment and conventional screens are unable to reliably ensure the solids retention required for wash water. Finer screens are an efficient and economical solution to mechanically eliminate high solids concentrations.

In particular the hollow fibre membranes recently available on the market may block with hairs or other fibrous material with the result of reduced membrane permeability. Fine screens with very fine apertures are able to remove such material and thus ensure a trouble-free and maintenance-free operation of the subsequent membrane plant.

►► The solution

The ROTAMAT® Pipestrainer is a fine screen designed to handle small municipal and industrial wastewater flows of up to 7 l/s and can also be used as a sludge thickener for small throughputs. Due to its small space requirements, the wastewater to be treated can be screened at source.

►► The function

The ROTAMAT® Pipestrainer is a horizontal pipe-shaped fine material separator consisting of a screening zone and a discharge section with pressure cone and pressure cone adjusting system.

The screening zone consists of a screw which rotates inside a screen basket and transports the solids retained on the screen surface up to the screenings discharge. The wastewater to be treated flows through the screen surface from inside to outside and is then discharged vertically downwards through an outlet pipe connection. The screen basket can be equipped with different filter elements and thus adapted to suit specific requirements with the screen surface mechanically cleaned by brushes fitted to the screw and backwashing with water is not required.

The screenings that have been transported to the screenings discharge by the screw are pushed against a pressure cone. The screenings dewatering efficiency is determined by the spring force adjusted at the pressure cone, i.e. it depends on the pre-load on the spring regarding how wide the annular discharge gap will open. The spring force is generated by means of pressure air and cylinders. If required by the quality of the wastewater to be screened the pressure cone can intermittently be opened completely to allow for discharge of accumulated screenings. The Pipestrainer can easily be integrated within a pipeline system with automatic operation of the system.

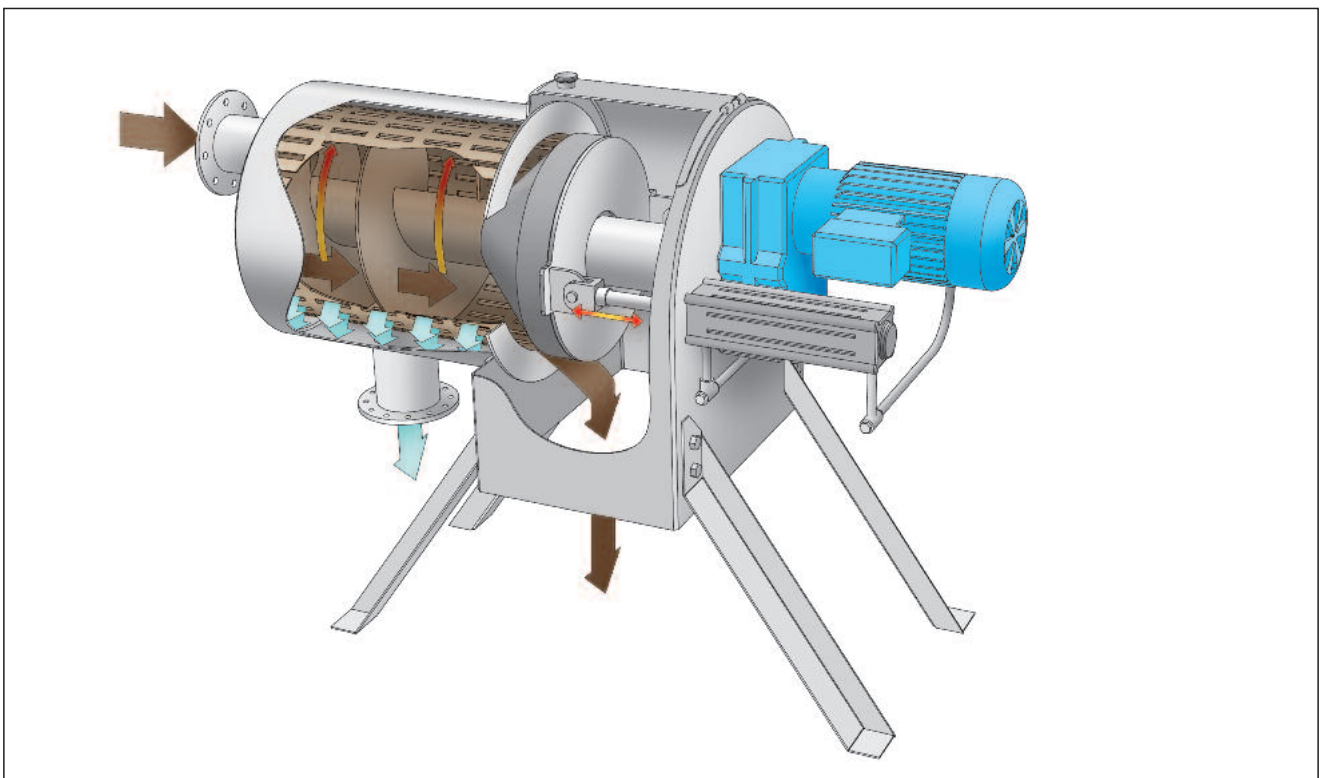

►► The applications

The ROTAMAT® Pipestrainer is a mechanical preliminary screen for small municipal and industrial wastewater flows of up to 7 l/s that can also be used as a sludge thickener for small throughputs (1.5 m³/h) and is designed specifically for these tasks. Due to its small footprint requirements it allows mechanical treatment of the wastewater or sludge at source.

- Wastewater screening prior to membrane plants
The wastewater to be treated by the membrane plants must be free of hairs, fibres and suspended material that may otherwise lead to undesired tressing and consequently functional and operational problems.
- Preparation of service and wash water
Wastewater preparation is increasingly demanded to achieve recycling and reuse of the valuable resource water with particular importance in the removal of hairs and fibres.

- Product recovery
Product recovery will gain increasing importance in the future due to tightening legislation and growing ecological awareness. The ROTAMAT® Pipestrainer retains valuable material for recovery and reuse, for example when screening brown water for later humus production or recovery of difficult to sediment gypsum for further processing.
- Paper and pulp industry: separation of fine fibres
- Water treatment in food and chemical industries
- Laundries: separation of fibres
- Tobacco industry: separation of tobacco residues from wastewater
- Agricultural industry: separation of fruit and residues from peelings
- Textile industry: recovery of fibrous material from production wastewater
- Thickening of flotata sludge and sludge from MBR plants



Screening of municipal wastewater with a high content of fibres (in particular toilet paper)



The ROTAMAT® Pipestrainer removes very fine screenings (such as hairs) after a preceding coarse screen

►► The user's benefits

- Small space requirements due to the compact, totally enclosed design and high hydraulic capacity
- No wash water requirement due to mechanical screen surface cleaning
- Protection of downstream treatment stages through reduction of filterable solids by up to 50%
- Minimum operator attendance required due to fully automatic operation
- Low-cost treatment of wash water or process water



ROTAMAT® Pipestrainer used for brown water screening for later humus recovery

►► Technical data

The ROTAMAT® Pipestrainer is manufactured in one standard size. The throughput of the unit is dependent upon inlet concentration and selected screen aperture but up to 7 l/s can be achieved with municipal wastewater. If used for sludge thickening, the ROTAMAT® Pipestrainer is able to handle throughputs of 1 to 5 m³/h. The standard material utilised for the complete casing and screen basket is stainless steel. Varying solids compositions can be optimally handled as the Pipestrainer's cone pressure is manually adjustable.

Screen basket elements	
Slot width (mm)	Perforated plate diameter (mm)
0.2 / 0.5 / 1.0	3

HUBER SE

Industriepark Erasbach A1 · D-92334 Berching
 Phone: + 49 - 84 62 - 201 - 0 · Fax: + 49 - 84 62 - 201 - 810
 info@huber.de · Internet: www.huber.de

Subject to technical modification
 1,5 / 3 – 8.2010 – 4.2005

ROTAMAT® Pipestrainer